

TBC1 Tooth Belt Conveyor Section
Instruction & Maintenance Manual
TBC1 齿形皮带输送段安装使用维护手册

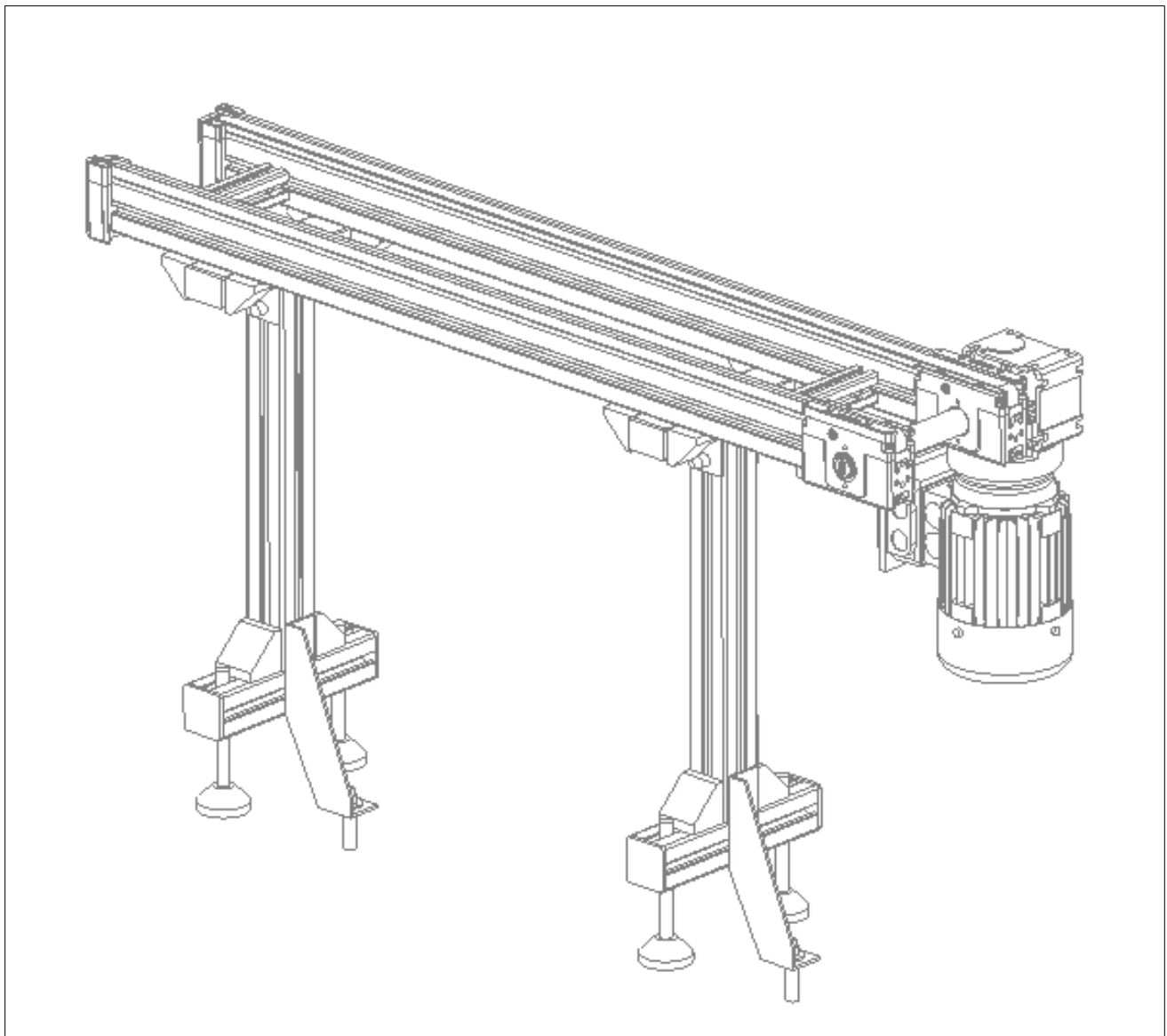

Suzhou LinkedGo Transfer System Co.,Ltd.

苏州领科工业技术有限公司

Structure Diagram 结构示意图

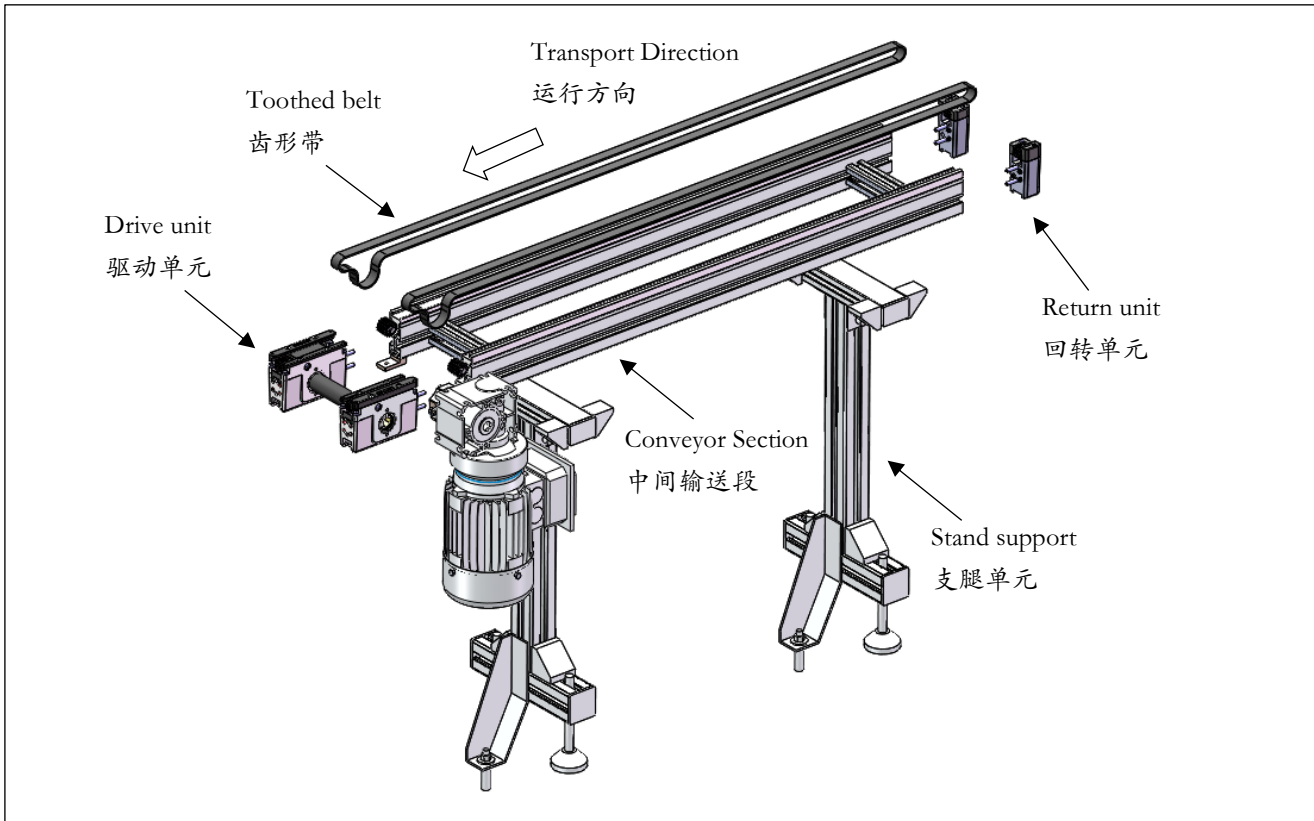

产品特征

安装步骤

- 1、 The length L of the straight section is 250-5000mm, and the width can be customized according to customer requirements.
- 1、 直线段长度 L 为 250-5000mm， 宽度可根据客户要求定制。
- 2、 The conveying medium is a toothed belt.
- 2、 输送介质为齿形皮带。
- 3、 The maximum conveying section load during stacking operation is 30kg.
- 3、 堆积操作中的最大输送段负载为 30kg。
- 4、 Can run in reverse.
- 4、 可反向运行。
- 5、 The motor can be installed on the right, left, and middle of the line * (* when the conveying section width $B \geq 160$ mm).
- 5、 电机可安装在线体右侧、左侧和中间* (*当输送段宽度 $B \geq 160$ mm)。

维护保养

Model Description 型号说明

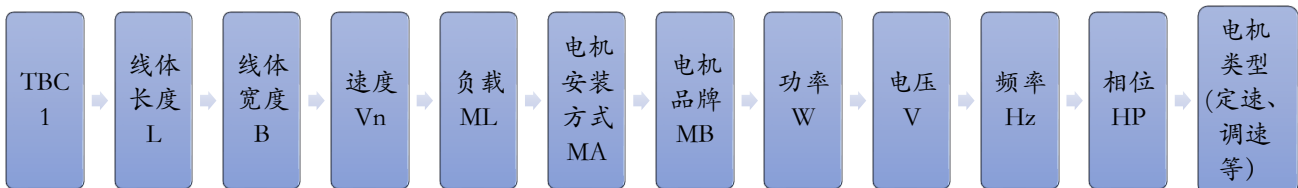

例：TBC1 - L2810 - B120 - Vn12 - ML30 - MAL011A - NORD - 120W - 380V - 50Hz - 3HP - C0

The model TBC1-L2810-B120-Vn12-ML30-MAR011A-NORD-120W-380V-50Hz-3HP-C0 represents a fixed speed motor with a line length of 2810mm, a line width of 120mm, a running speed of 12m/min, a running load of 30kg, a motor installation position of L011A, a motor brand of NORD, a power of 120W, a voltage of 380V, a frequency of 50Hz, and a phase of 3.

型号 TBC1-L2810-B120-Vn12-ML30-MAR011A-NORD-120W-380V-50Hz-3HP-C0, 表示线体长度 2810mm, 线体宽度 120mm, 运行速度 12m/min, 运行负载 30kg, 电机安装位置为 L011A, 电机品牌为 NORD, 功率为 120W, 电压为 380V, 频率为 50Hz, 相位为 3 的定速电机。

参数说明 Parameter Description

品名 Product Name	长度(mm) Length	宽度(mm) Width	速度(m/min) Speed	电机安装方式 Motor installation method
TBC1	250~5000	80~160	8~20	电机安装: MA=①_②_③_④_⑤_ Motor installation: MA=①_②_③_④_⑤_ ①电机安装位置: M 中置; R=右; L=左; Motor installation position: M center; R=right; L=Left; ②当①=R/L 时, ②=0; 当①=M 时, ②=R/L; ② When ①=R/L, ②=0; When ①=M, ②=R/L; ③电机安装位置: 1、2、3、4; Motor installation position: 1, 2, 3, 4; ④接线盒位置: 1、2、3、4; Location of junction box: 1, 2, 3, 4; ⑤出线口方向: A、B、C、D; Outlet direction: A, B, C, D;

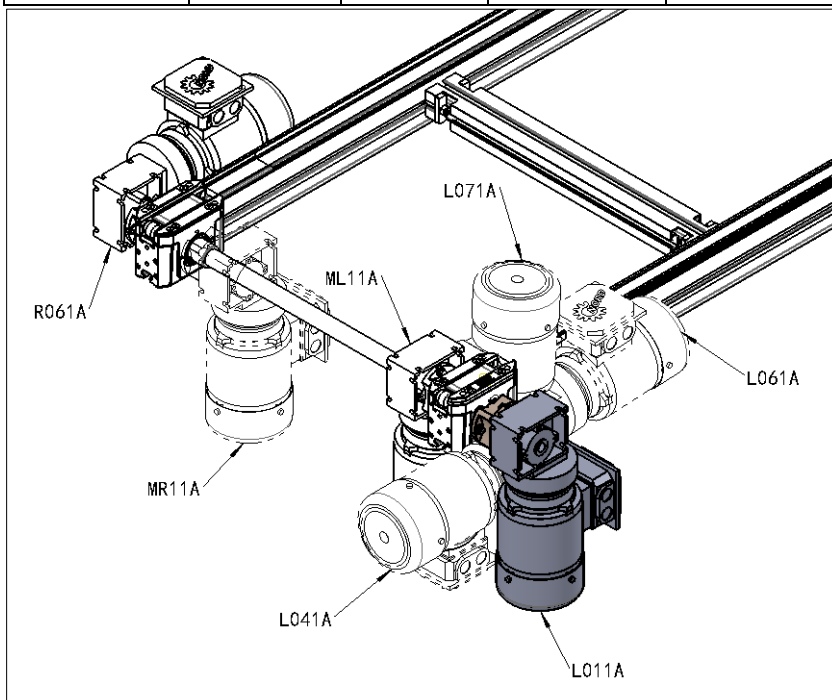

Note: The figure shows the installation position of motor L011A.

注: 图为电机 L011A 的安装位置。

安装步骤 Installation steps

A Install the body profile as shown in the following figure.

A 按下图所示，安装机身型材。

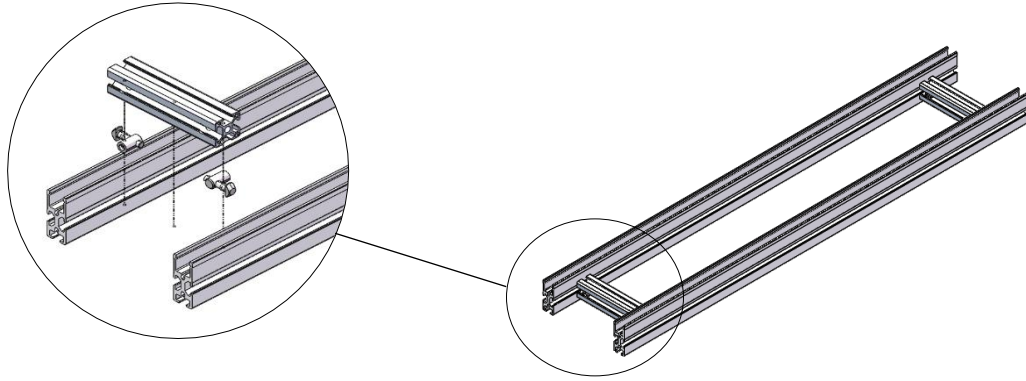

B Assemble the stand support onto the Conveyor Section as indicated below.

B 按下图所示，将支腿单元安装到中间输送段上。

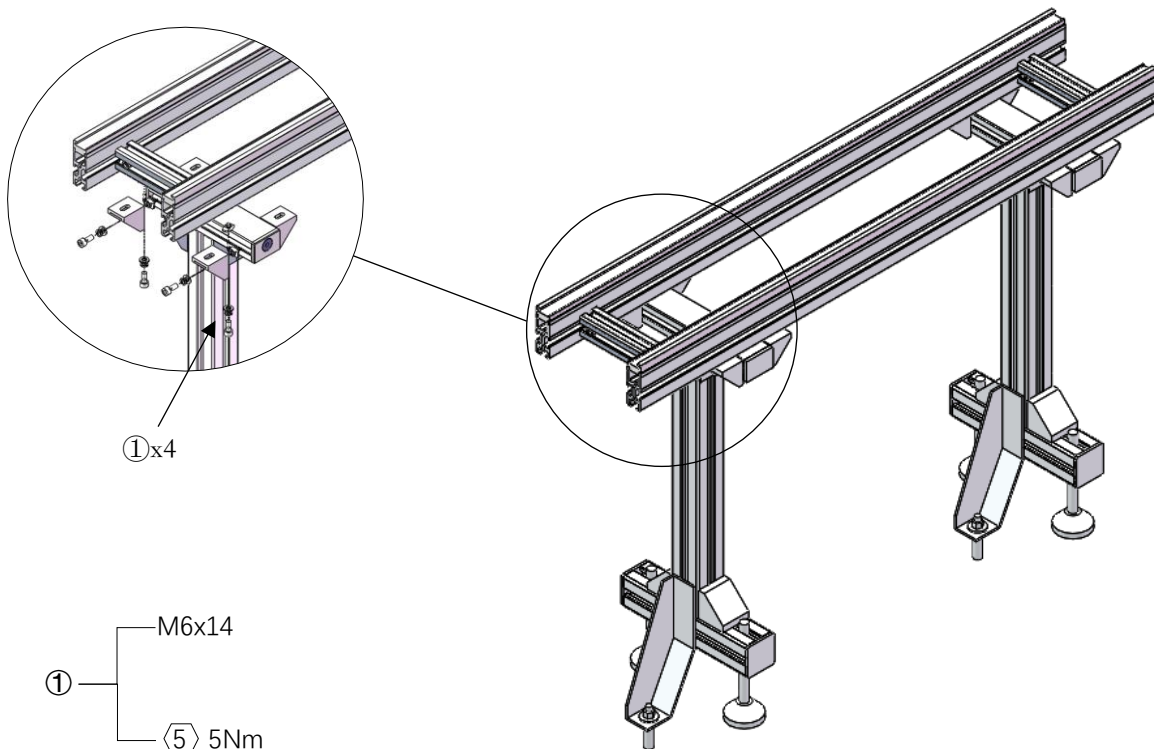

C Assemble the lower cover of drive unit, return unit onto two ends of conveyor body.

C 按下图所示，将驱动单元下壳体、回转单元安装于线体两端。

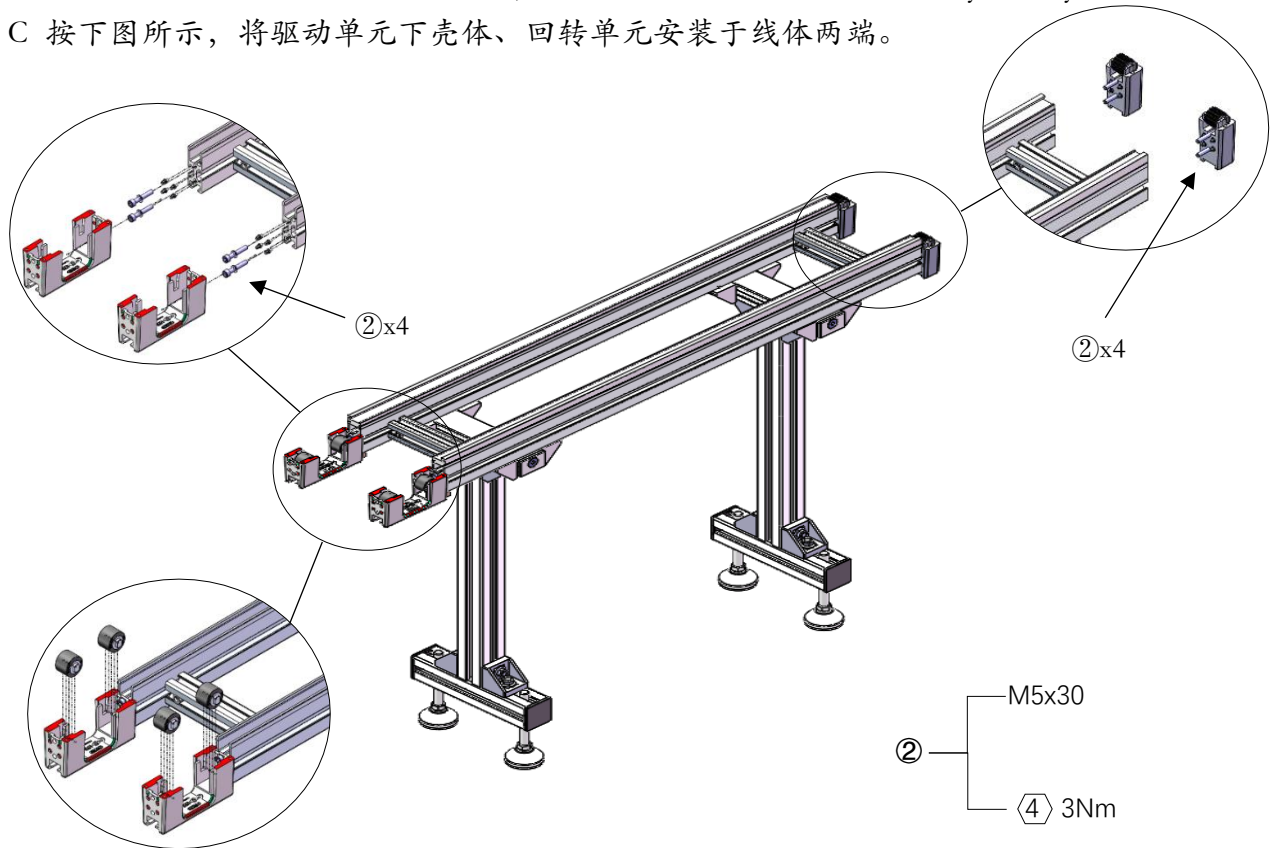

D Put the toothed belt into the profile slot and make the belt flat. Then install the friction strip on the frame profile.

D 将齿形带沿线体型材放入型材槽口内，使其平整。将线体磨擦条卡扣在线体型材上。

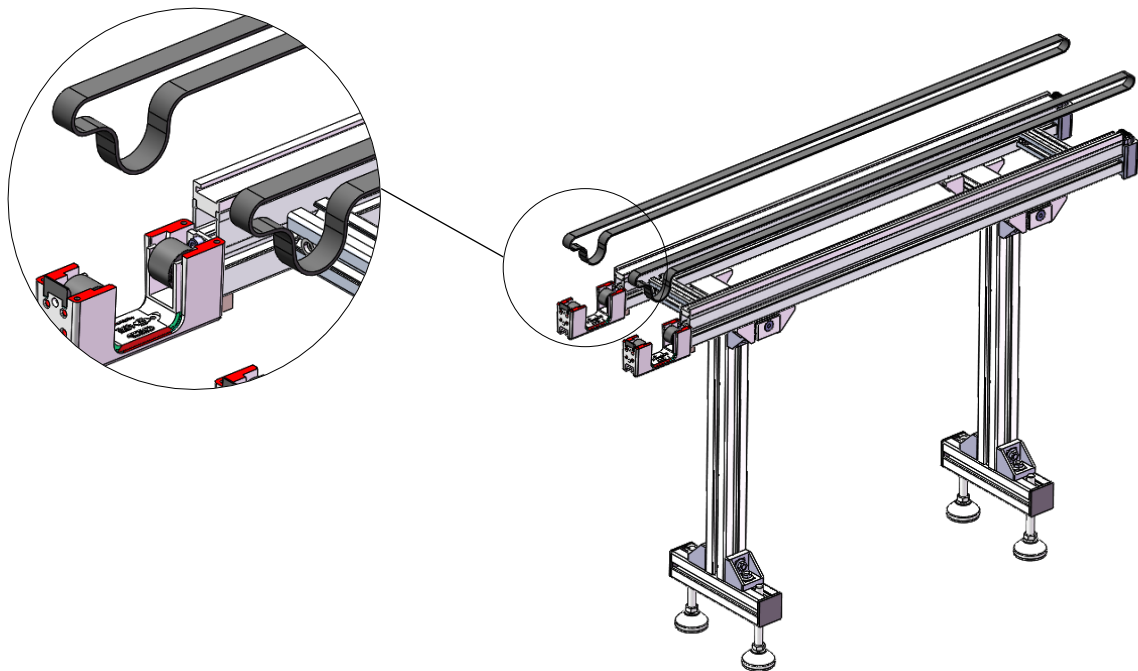

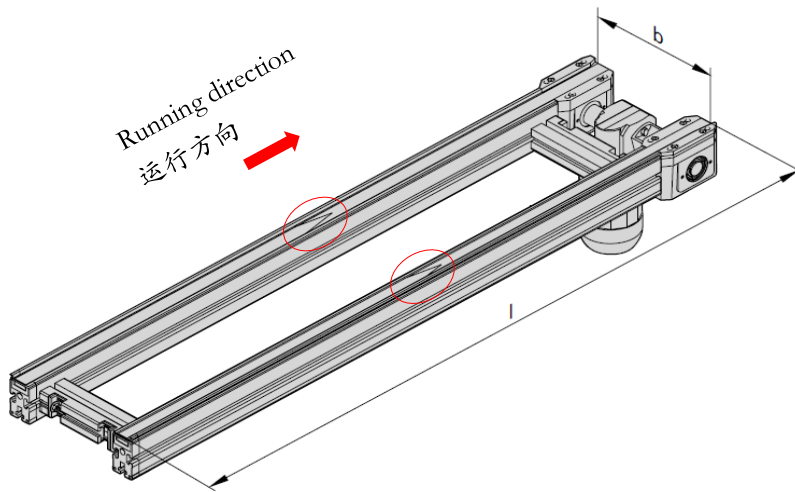

Note:

When installing the belt, the direction of the belt connection should be consistent with the direction of the line operation.

请注意：

安装皮带时，皮带接驳朝向应与线体运行方向保持一致。

E Install the T-type bearing seat, transmission shaft, and other accessories of the drive unit as shown In the following figure. After assembly, place the assembled T-shaped bearing seat and other accessories into the lower housing, assemble the pulley components of the drive unit and rotary unit, and place the toothed belt.

E 按下图所示，安装驱动单元 T 字型轴承座、传动轴及其他附件。组装完成后，将装好的 T 字型轴承座及其他附件放入下壳体，组装驱动单元及回转单元的滑轮组件并放置齿形带。

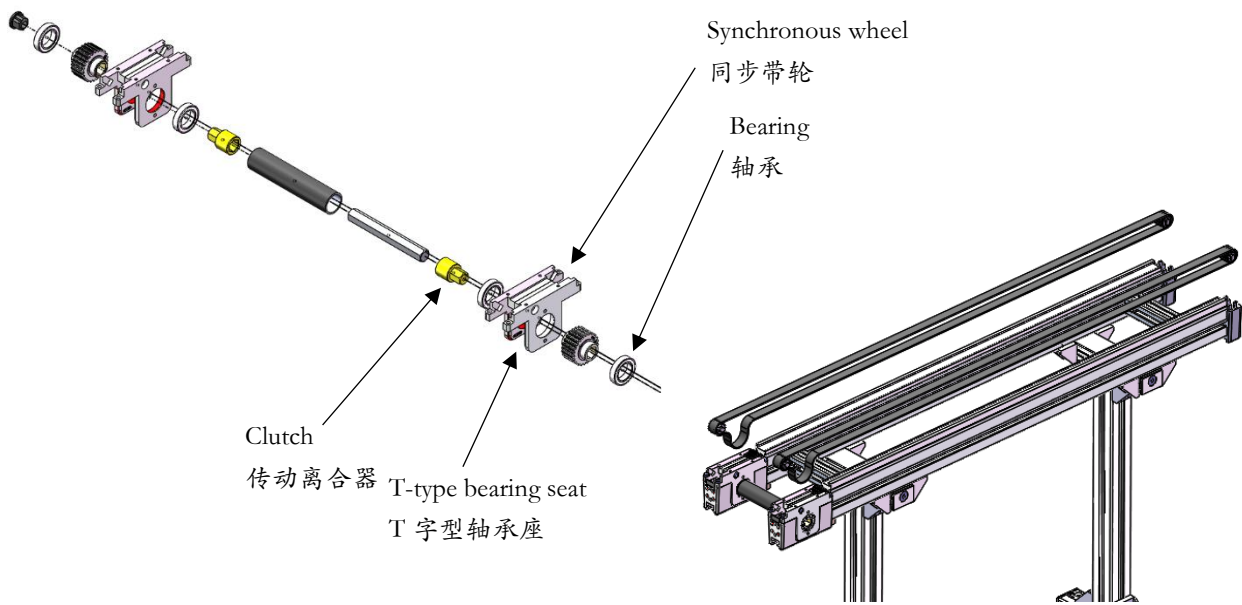

Note: The toothed belt bypasses the pulleys of the drive unit and rotary unit, as shown in the left figure. Please pay attention to the installation direction of the pulleys.

注意：齿形带绕过驱动单元和回转单元滑轮，绕行方式见左图，需注意滑轮的安装方向。

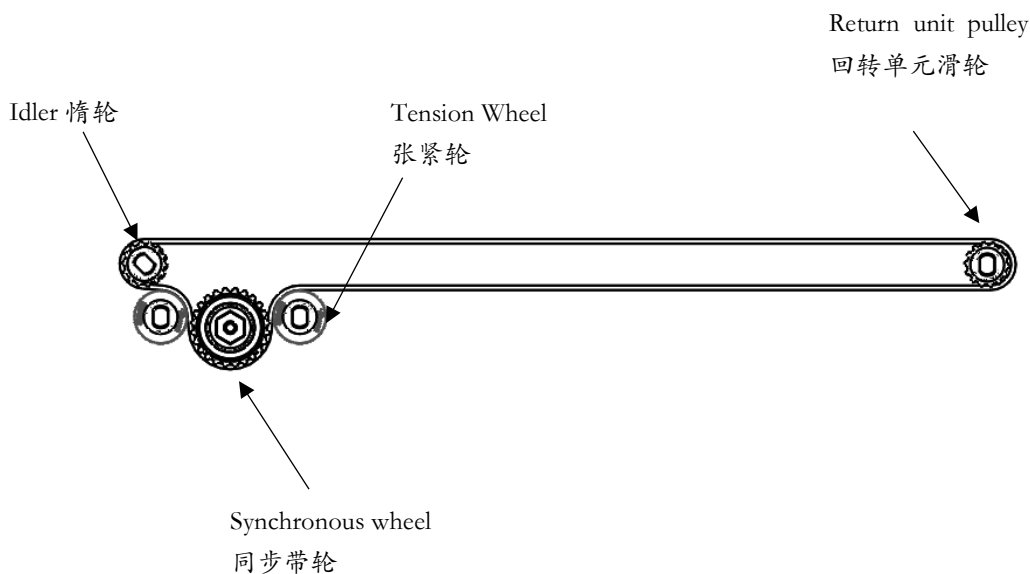

F Installing the motor.

F 安装电机

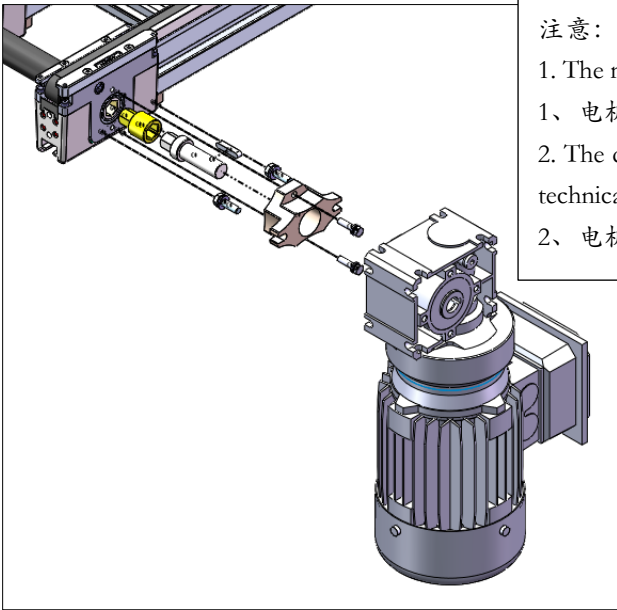

Attention:

注意:

1. The motor should be installed firmly and not tilted.
- 1、电机安装稳固不能倾斜。
2. The direction of the motor and junction box must meet the technical requirements.
- 2、电机与接线盒方向必须符合技术要求。

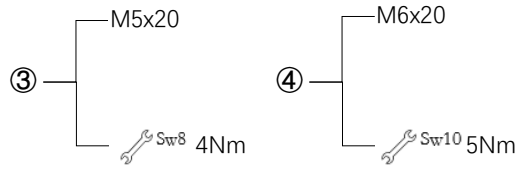

G Install the drive unit and rotary unit cover plate.

G 安装驱动单元、回转单元盖板。

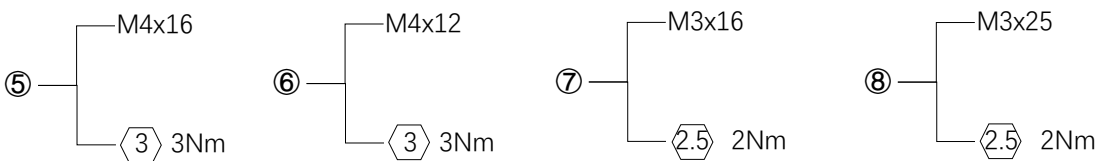
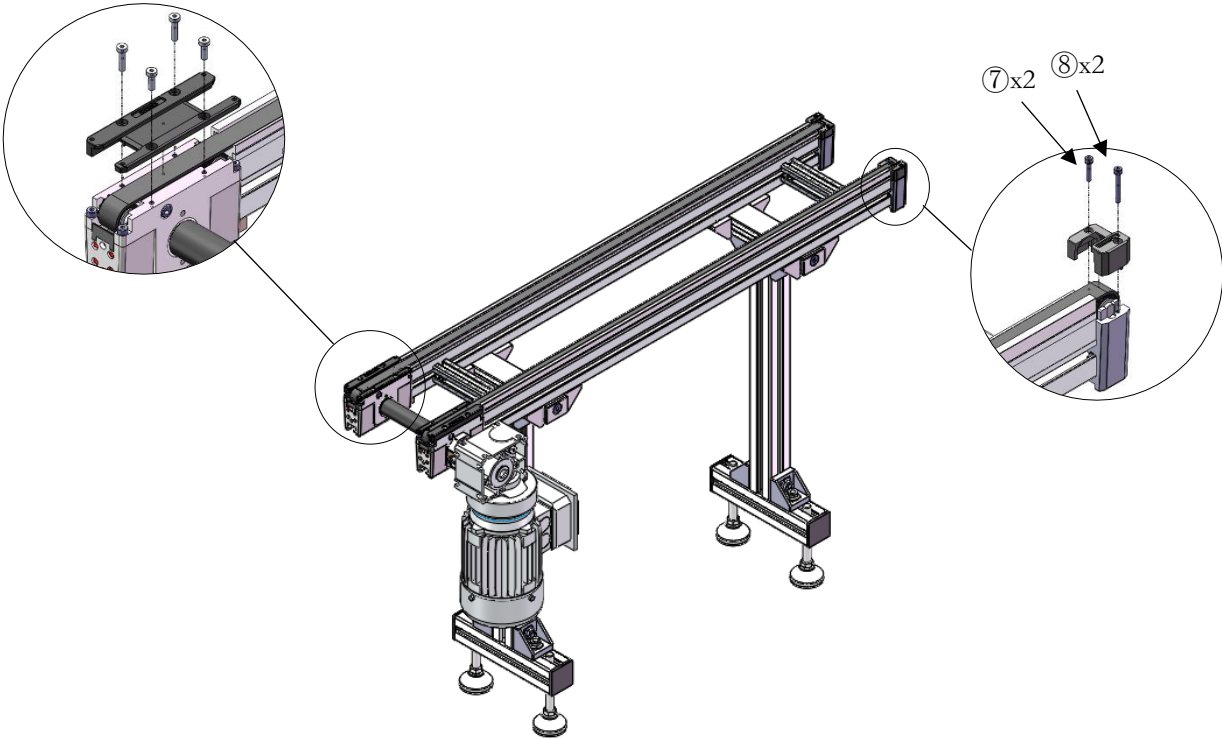

Maintenance 维护和保养

The UTS series tray conveying system requires regular maintenance and upkeep to extend the service life of the line. The conveying equipment should be kept clean to avoid direct sunlight or rain or snow, and to prevent contact with substances such as acids, alkalis, oils, organic solvents, etc.

UTS 系列托盘输送系统需按周期进行规定的保养维护工作，以延长线体使用寿命。输送设备应保持清洁避免阳光直射或雨雪浸淋，防止与酸、碱、油类、有机溶剂等物质接触。维护前需关闭对应的能源供给。

Daily Maintenance

日维护

Regularly clean the conveyor line. Before starting the machine every day, it is necessary to clean the floating dust, falling small parts, and other obstacles on the belt and wire body to prevent dust and dirt from affecting the operation of the wire body. When cleaning the machine head, it is necessary to remove the upper cover of the machine head, pick up the T-shaped bearing seat, and use an air gun to remove the accumulated dust inside. During trial operation, check whether there are any abnormalities in various parts of the conveyor line, such as loose bearings or abnormal noise. Once any abnormalities are found, repair and replace them immediately. Check the belt daily for burrs, stretching deformation, tearing, wire breakage, wear, and looseness, and make timely adjustments, repairs, or replacements.

定期清洁输送线。每日开机前需清理皮带及线体上的浮尘、掉落的小零件及其他障碍物，防止积尘和污垢影响线体运行。在清洁机头时，需拆掉机头上盖，拿起T型轴承座，用气枪清除里面积压的灰尘。试运行前，检查输送线的各部位是否有异常，如轴承有无松动或异常噪音，一旦发现异常应即使维修和更换。每日检查皮带是否有毛边、拉伸变形、撕裂断丝、磨损和松动等情况，及时调整维修或更换。

Weekly Maintenance

周维护

Regularly inspect the accessories on the conveyor line body. For parts that are prone to damage such as synchronous wheels, bearings, and idlers, regular inspection, maintenance, and lubrication are required. If damage or looseness is found, it must be replaced immediately. Check if the fasteners on the wire body are loose and tighten them in a timely manner.

定期检查输送线体上的附件。对于同步轮、轴承、惰轮等容易损坏的零件，需定期检查、保养和润滑。发现损坏和松动须立即更换。检查线体上的紧固件是否有松动情况，及时紧固。

Monthly Maintenance

月维护

Regularly clean motor bearings, check for wear, and replace lubricating oil in a timely manner. (It is necessary to replenish the oil at any time based on the on-site operating conditions and the degree of oil volatilization. Under normal operation, the lubricating oil can be replaced every six months.)

对于电机轴承等定期清洗，检查磨损情况，及时更换润滑油。（需根据现场运行状况及油脂挥

发程度进行随时补油，正常运行下，可六个月更换一次润滑油。)

产品特征

安装步骤

维护保养

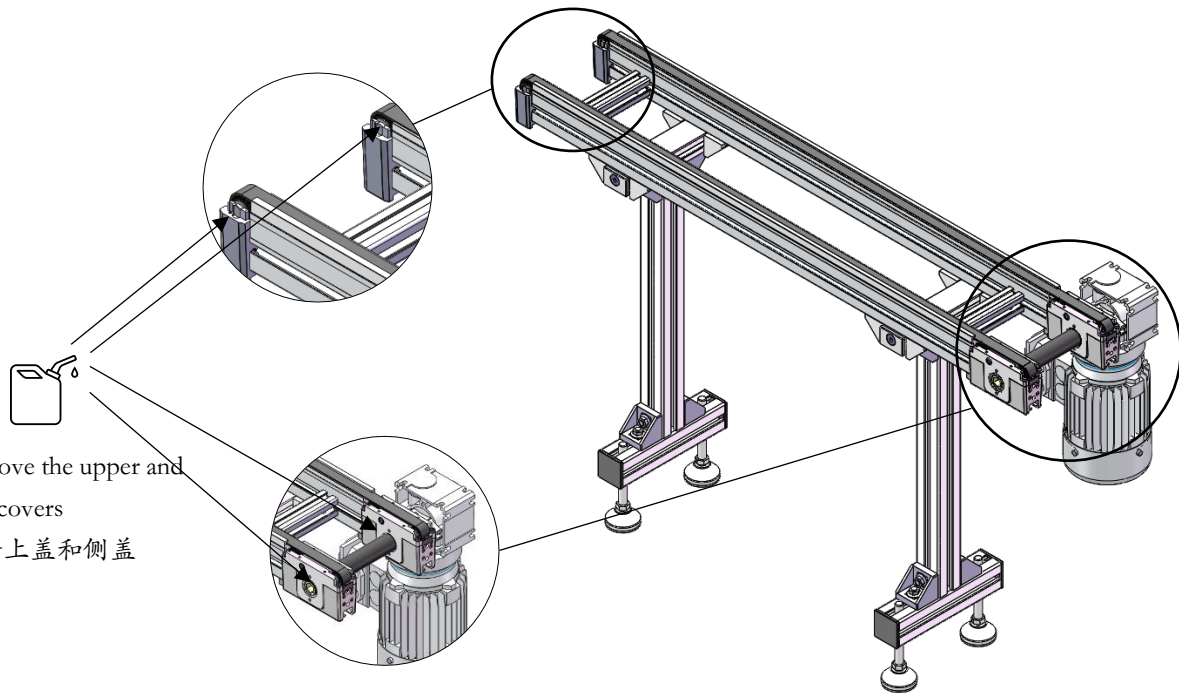

Remove the upper and side covers
拆除上盖和侧盖

Quarterly maintenance

季度维护

Check if the guide strip and friction strip are severely worn or deformed, and replace them in a timely manner. Confirm that the operation is in good condition, without any belt jamming, slipping, deviation, or abnormal noise from the wire body. If this situation occurs, it is necessary to check whether the internal structure of the drive unit and rotary unit is intact.

检查导向条、磨擦条是否磨损严重或者变形，并及时更换。确定运行状况良好，无皮带卡顿、打滑、偏移及线体异响的情况发生，如有此情况，需检查驱动单元、回转单元是否内部结构完好。

Note:

During the installation process of the conveyor line, it is also important to maintain factors such as the levelness, verticality, and tension of the belt line to prevent friction, looseness, and twisting caused by improper installation. During operation, it is necessary to operate at the specified speed and load to ensure the normal operation of the belt line.

注：

在输送线的安装过程中，保持皮带线的水平度、垂直度、张力等因素也很重要，可防止因安装不当而引起的摩擦、松动、扭曲等问题。在运行过程中，须按规定的速度、负载运行，确保皮带线的正常运行。

Disclaimer

免责声明

The customer shall inspect the equipment regularly. If the customer fails to maintain the conveyor as the state above, leading to any malfunction or damage to the conveyor, our company will not be responsible for it, all related costs (including material costs, installation and commissioning fees, and hotel expense) shall be borne by the customer.

客户应定期对设备进行检查。若客户未按要求对输送机进行维护，进而导致输送机发生任何故障或损坏，我司将不承担相关责任，由此产生的相关费用（材料费，安装调试费，差旅费）均由客户承担。

Suzhou LinkedGo Transfer System Co.,Ltd.
苏州领科工业技术有限公司

[Tel: +86-512-6636 1885](tel:+86-512-66361885)

Add: Room 706, Building D, Dongchuang Science and Technology Park,
No. 216 Jinfeng Road, Wuzhong District, Suzhou, P.R. China
Zip code:215101

E-mail: Sales@LinkedGo.com.cn

Website: [www. LinkedGo.com.cn](http://www.LinkGo.com.cn)

Subject to technical modifications

电话: +86-512-6636 1885

地址: 苏州市吴中区木渎镇金枫路 216 号东创科技园 D 幢 706 室

邮编: 215101

邮箱: Sales@LinkedGo.com.cn

网址: www.LinkGo.com.cn

我司保留技术更改的权利